

*A. Edmonds,
Gage Lathe,*

Nº 17,782,

Patented July 14, 1857.

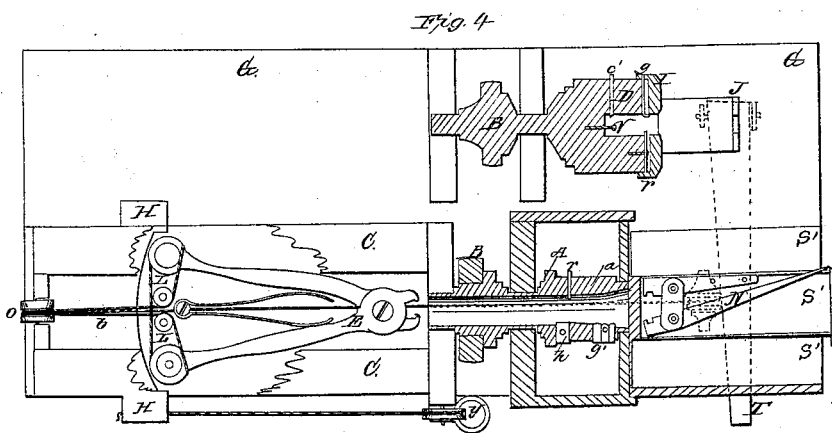
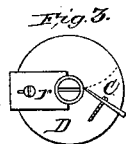
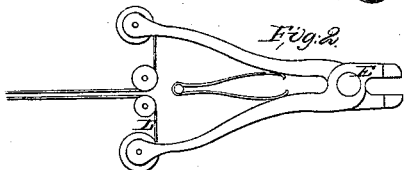
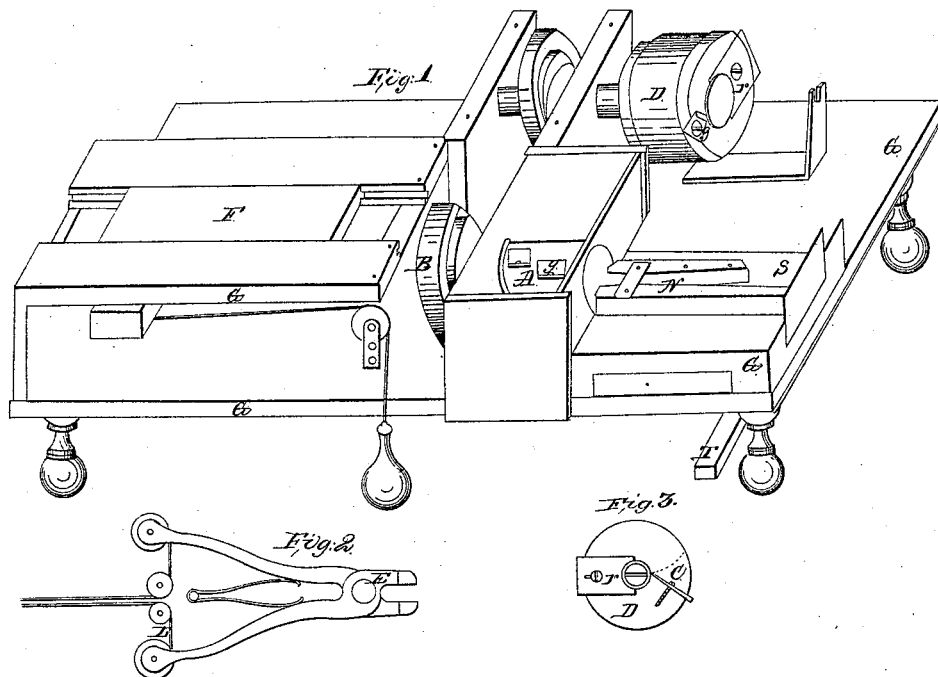

UNITED STATES PATENT OFFICE.

ALEXANDER EDMONDS, OF MOUNT PULASKI, ILLINOIS.

AUTOMATIC LATHE.

Specification of Letters Patent No. 17,782, dated July 14, 1857.

To all whom it may concern:

Be it known that I, ALEXANDER EDMONDS, of Mount Pulaski, in the county of Logan and State of Illinois, have invented certain new and useful Improvements in Machines for Turning; and I do hereby declare that the following is a full and exact description thereof, reference being had to the accompanying drawings, and to the letters of reference marked thereon, forming part of this patent.

Figure 1 (first sheet) is an oblique view as seen from above the machine; Fig. 2, a plan of the nippers; Fig. 3, a front view of the tenoning machine, the cap removed. Fig. 4 (second sheet) is a horizontal view, part in section, and having the slide F of Fig. 1 removed.

The nature of my improvement consists in constructing a turning machine, by which on taking pieces of wood from the rough and placing it in a pair of nippers or tongs on the one side, and forcing it through a hollow rotating shaft (provided with cutters, &c.) it is received on the opposite side thereof by another pair of nippers actuated by the foot and drawn through the machine; by my improvement in the tenoning machine, I am able to finish these cylinders, with a proper shoulder, chamfer taken off and regular size, fit for chair makers' use.

To enable others skilled in the art to make and use my machine, I will proceed to describe its construction and use.

In Fig. 1, G G is the frame or platform of the machine, supported at a convenient height by four pillars; in suitable puppets and driven by a pulley B is placed a hollow shaft or rotating stock A *a*, it is formed of two portions, the outer one *a*, Fig. 4, is trumpet shape in the mouth, and is there provided with one or more gouges *g* behind which may be placed the gage. A second piece A is provided with a finishing chisel *h*. Upon the face of the piece A is placed a gage plate *r* (similar to *r* in Fig. 3, the tenoning tool) by moving *r* toward the chisels the diameter of the turned stuff is regulated or the gage may be placed directly behind *g*. If small rounds are wanted force the plate toward the center of the hollow shaft. The chisel gage and gouges are secured in the stock by screws and are fur-

nished with suitable openings to discharge the chips.

C, C, are parallel pieces raised upon the platform G G. On their inner edges are grooves in which slide the pieces F, Fig. 1. On the under side of F is secured the spring nippers or tongs E, connected with and operated on by the treadle T, by cords which pass over a pulley *o*, through the platform G, and around the ends of the nippers; by drawing on the cords the nippers are made to close and hold the stuff.

N is a pair of hand nippers or tongs, placed on the upper side of a slide S between S' S', it is to force up and hold the stuff while being turned.

Y is a counter weight, drawing the cross piece H of the slide F and nippers E back to the shaft A *a*, when relieved of the treadle T.

The tenoning machine is composed of rotating shaft AD provided with a gouge *g*, Fig. 4, for cutting ridges, a gage *r* (also in Fig. 3), formed of a plate with a semicircular notch.

C' is a bevel edged chisel to take off the chamfer of the tenon; V a movable screw in the cup or bottom of the hollow shaft by turning it in or out, regulates the length of the tenon.

I is a guide cap placed on the mouth of the cutter for the end of the tenon; J a rest for the other end of the tenon; B a driving pulley.

In using the machine for turning, take a piece of wood, a square or other shape, withdraw the slide S and nippers N to receive the piece, enter the piece in the conical mouth of the stock or shaft and press it through and present the end of the round to the open jaws of the foot nipper E. By placing the foot on the treadle T the jaws are closed upon and hold the piece, and at the same time the frame F is made to draw back, carrying with it the nippers and piece and raising the counter weight Y. When through the foot is withdrawn and the weight brings the sliding frame back to its place. The rounds are afterward placed and held by hand in the tenoning machine, and thus finished ready for use.

What I claim as my invention, and desire to secure by Letters Patent, is—

1. The combination of the rotating cutter

55

60

65

70

75

80

85

90

95

100

105

A *a* provided with a gage *r*, regulating the diameter of the rounds or cylinders, with the nippers N and E for forming chair stuff.

2. Also I claim the arrangement in the
5 tenoning machine of the regulating screw V and cap I with the chamfer chisel C', for the purpose set forth.

In testimony whereof I have hereunto signed my name before two subscribing witnesses.

ALEXANDER EDMONDS.

Witnesses:

DAVID L. WATERS, Jr.,
JOHN T. CLARK.